

# LM741

## Single Operational Amplifier

### Features

- Short circuit protection
- Excellent temperature stability
- Internal frequency compensation
- High Input voltage range
- Null of offset

### Description

The LM741 series are general purpose operational amplifiers. It is intended for a wide range of analog applications. The high gain and wide range of operating voltage provide superior performance in integrator, summing amplifier, and general feedback applications.

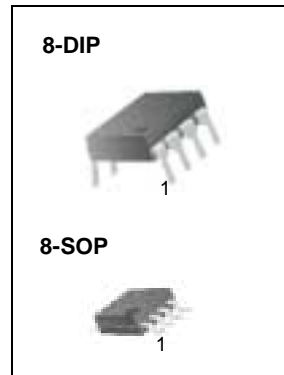

### Internal Block Diagram

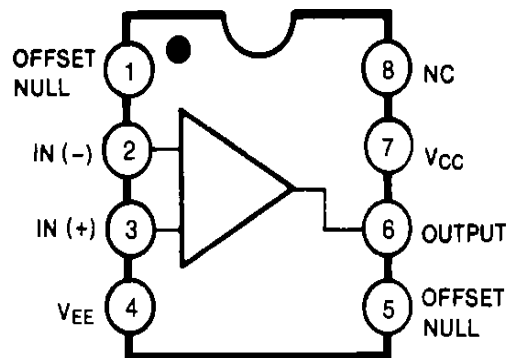

## Schematic Diagram

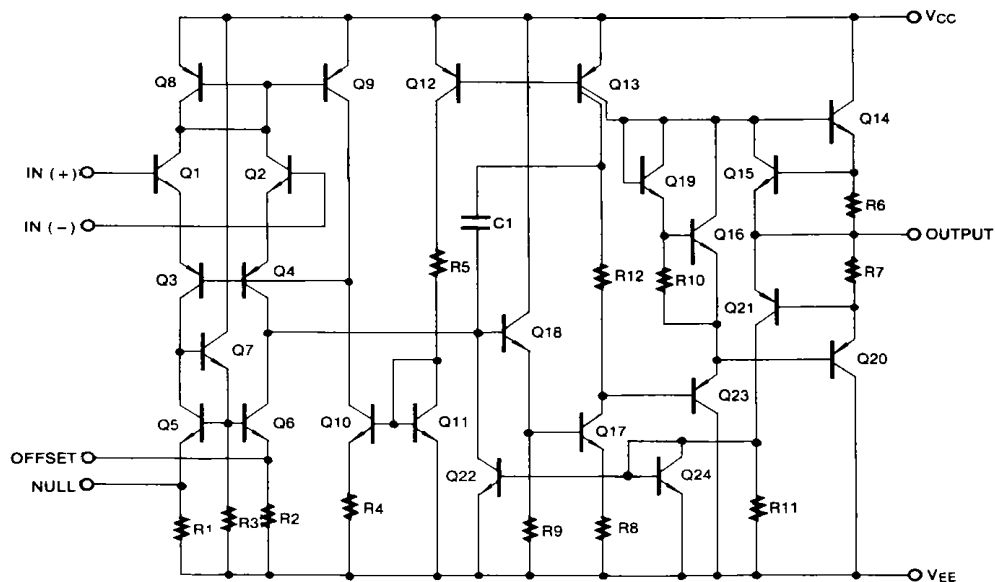

## Absolute Maximum Ratings (TA = 25°C)

Parameter	Symbol	Value	Unit
Supply Voltage	VCC	±18	V
Differential Input Voltage	VI(DIFF)	30	V
Input Voltage	VI	±15	V
Output Short Circuit Duration	-	Indefinite	-
Power Dissipation	PD	500	mW
Operating Temperature Range LM741C LM741I	TOPR	0 ~ +70 -40 ~ +85	°C
Storage Temperature Range	TSTG	-65 ~ +150	°C

## Electrical Characteristics

( $V_{CC} = 15V$ ,  $V_{EE} = -15V$ .  $T_A = 25^\circ C$ , unless otherwise specified)

Parameter		Symbol	Conditions	LM741C/LM741I			Unit
				Min.	Typ.	Max.	
Input Offset Voltage	$V_{IO}$		$R_S \leq 10K\Omega$	-	2.0	6.0	mV
			$R_S \leq 50\Omega$	-	-	-	
Input Offset Voltage Adjustment Range	$V_{IO(R)}$		$V_{CC} = \pm 20V$	-	$\pm 15$	-	mV
Input Offset Current	$I_{IO}$		-	-	20	200	nA
Input Bias Current	$I_{BIAS}$		-	-	80	500	nA
Input Resistance (Note1)	$R_I$		$V_{CC} = \pm 20V$	0.3	2.0	-	$M\Omega$
Input Voltage Range	$V_{I(R)}$		-	$\pm 12$	$\pm 13$	-	V
Large Signal Voltage Gain	$G_V$	$R_L \geq 2K\Omega$	$V_{CC} = \pm 20V$ , $V_{O(P-P)} = \pm 15V$	-	-	-	V/mV
			$V_{CC} = \pm 15V$ , $V_{O(P-P)} = \pm 10V$	20	200	-	
Output Short Circuit Current	$I_{SC}$		-	-	25	-	mA
Output Voltage Swing	$V_{O(P-P)}$	$V_{CC} = \pm 20V$	$R_L \geq 10K\Omega$	-	-	-	V
			$R_L \geq 2K\Omega$	-	-	-	
		$V_{CC} = \pm 15V$	$R_L \geq 10K\Omega$	$\pm 12$	$\pm 14$	-	
			$R_L \geq 2K\Omega$	$\pm 10$	$\pm 13$	-	
Common Mode Rejection Ratio	CMRR	$R_S \leq 10K\Omega$ , $V_{CM} = \pm 12V$		70	90	-	dB
		$R_S \leq 50\Omega$ , $V_{CM} = \pm 12V$		-	-	-	
Power Supply Rejection Ratio	PSRR	$V_{CC} = \pm 15V$ to $V_{CC} = \pm 15V$ $R_S \leq 50\Omega$		-	-	-	dB
		$V_{CC} = \pm 15V$ to $V_{CC} = \pm 15V$ $R_S \leq 10K\Omega$		77	96	-	
Transient Response	Rise Time	$T_R$	Unity Gain	-	0.3	-	$\mu s$
	Overshoot	OS		-	10	-	%
Bandwidth		BW	-	-	-	-	MHz
Slew Rate		SR	Unity Gain	-	0.5	-	$V/\mu s$
Supply Current		$I_{CC}$	$R_L = \infty\Omega$	-	1.5	2.8	mA
Power Consumption	$P_C$	$V_{CC} = \pm 20V$		-	-	-	mW
		$V_{CC} = \pm 15V$		-	50	85	

Note:

1. Guaranteed by design.

## Electrical Characteristics

( $0^{\circ}\text{C} \leq T_A \leq 70^{\circ}\text{C}$   $V_{CC} = \pm 15\text{V}$ , unless otherwise specified)

The following specification apply over the range of  $0^{\circ}\text{C} \leq T_A \leq +70^{\circ}\text{C}$  for the LM741C; and the  $-40^{\circ}\text{C} \leq T_A \leq +85^{\circ}\text{C}$  for the LM741I

Parameter	Symbol	Conditions	LM741C/LM741I			Unit	
			Min.	Typ.	Max.		
Input Offset Voltage	$V_{IO}$	$R_S \leq 50\Omega$	-	-	-	mV	
		$R_S \leq 10\text{K}\Omega$	-	-	7.5		
Input Offset Voltage Drift	$\Delta V_{IO}/\Delta T$	-	-	-	-	$\mu\text{V}/^{\circ}\text{C}$	
Input Offset Current	$I_{IO}$	-	-	-	300	nA	
Input Offset Current Drift	$\Delta I_{IO}/\Delta T$	-	-	-	-	$\text{nA}/^{\circ}\text{C}$	
Input Bias Current	$I_{BIAS}$	-	-	-	0.8	$\mu\text{A}$	
Input Resistance (Note1)	$R_I$	$V_{CC} = \pm 20\text{V}$	-	-	-	$\text{M}\Omega$	
Input Voltage Range	$V_{I(R)}$	-	$\pm 12$	$\pm 13$	-	V	
Output Voltage Swing	$V_{O(P-P)}$	$V_{CC} = \pm 20\text{V}$	$R_S \geq 10\text{K}\Omega$	-	-	-	V
			$R_S \geq 2\text{K}\Omega$	-	-	-	
		$V_{CC} = \pm 15\text{V}$	$R_S \geq 10\text{K}\Omega$	$\pm 12$	$\pm 14$	-	
			$R_S \geq 2\text{K}\Omega$	$\pm 10$	$\pm 13$	-	
Output Short Circuit Current	$I_{SC}$	-	10	-	40	mA	
Common Mode Rejection Ratio	CMRR	$R_S \leq 10\text{K}\Omega$ , $V_{CM} = \pm 12\text{V}$	70	90	-	dB	
		$R_S \leq 50\Omega$ , $V_{CM} = \pm 12\text{V}$	-	-	-		
Power Supply Rejection Ratio	PSRR	$V_{CC} = \pm 20\text{V}$ to $\pm 5\text{V}$	$R_S \leq 50\Omega$	-	-	-	dB
			$R_S \leq 10\text{K}\Omega$	77	96	-	
Large Signal Voltage Gain	$G_V$	$R_S \geq 2\text{K}\Omega$	$V_{CC} = \pm 20\text{V}$ , $V_{O(P-P)} = \pm 15\text{V}$	-	-	-	V/mV
			$V_{CC} = \pm 15\text{V}$ , $V_{O(P-P)} = \pm 10\text{V}$	15	-	-	
			$V_{CC} = \pm 15\text{V}$ , $V_{O(P-P)} = \pm 2\text{V}$	-	-	-	

Note :

1. Guaranteed by design.