

S2 Robot Electrical Schematics

Public Release: 09DEC2010
 Subversion Rev: 2271

PDF Viewing Notes:

The Net Names & Components are Hyper Linked.
 Left Click on a Component to view additional information.
 Left Click on a Net Name to follow it through the design.

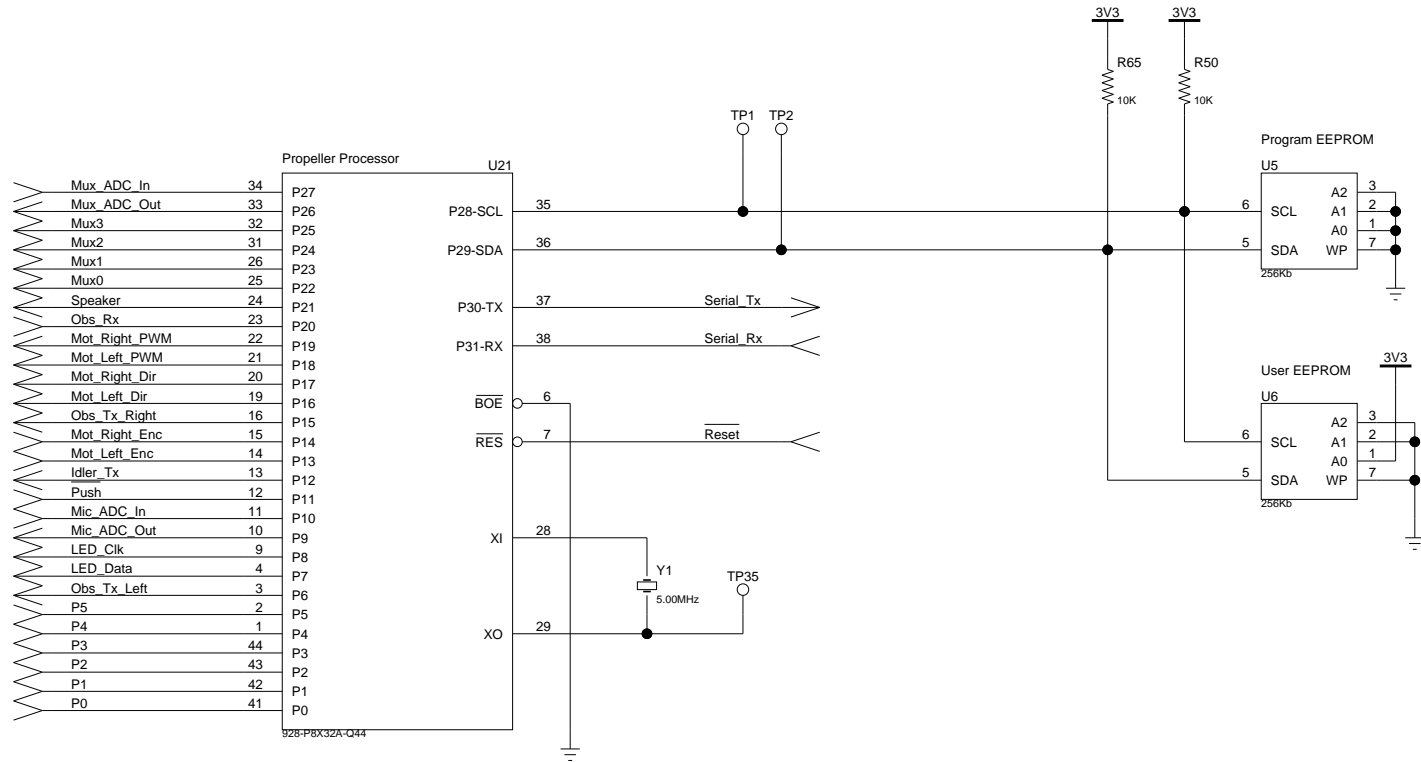

Mounting Holes

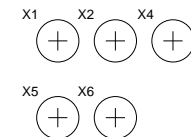

Designer: Ben Wirz
 Element Products, Inc.
<http://www.elementinc.com/>

Copyright(c) 2010 Element Products, Inc. & Parallax, Inc.
 This schematic is released under the Creative Commons
 Attribution License. (www.creativecommons.org)

SIZE	DWG	10712D_Main_PCB	
A			
DRAWN BY	SHEET	OF	PROJECT
B. WIRZ	1	8	SCRIBBLER2

Back Board Interface

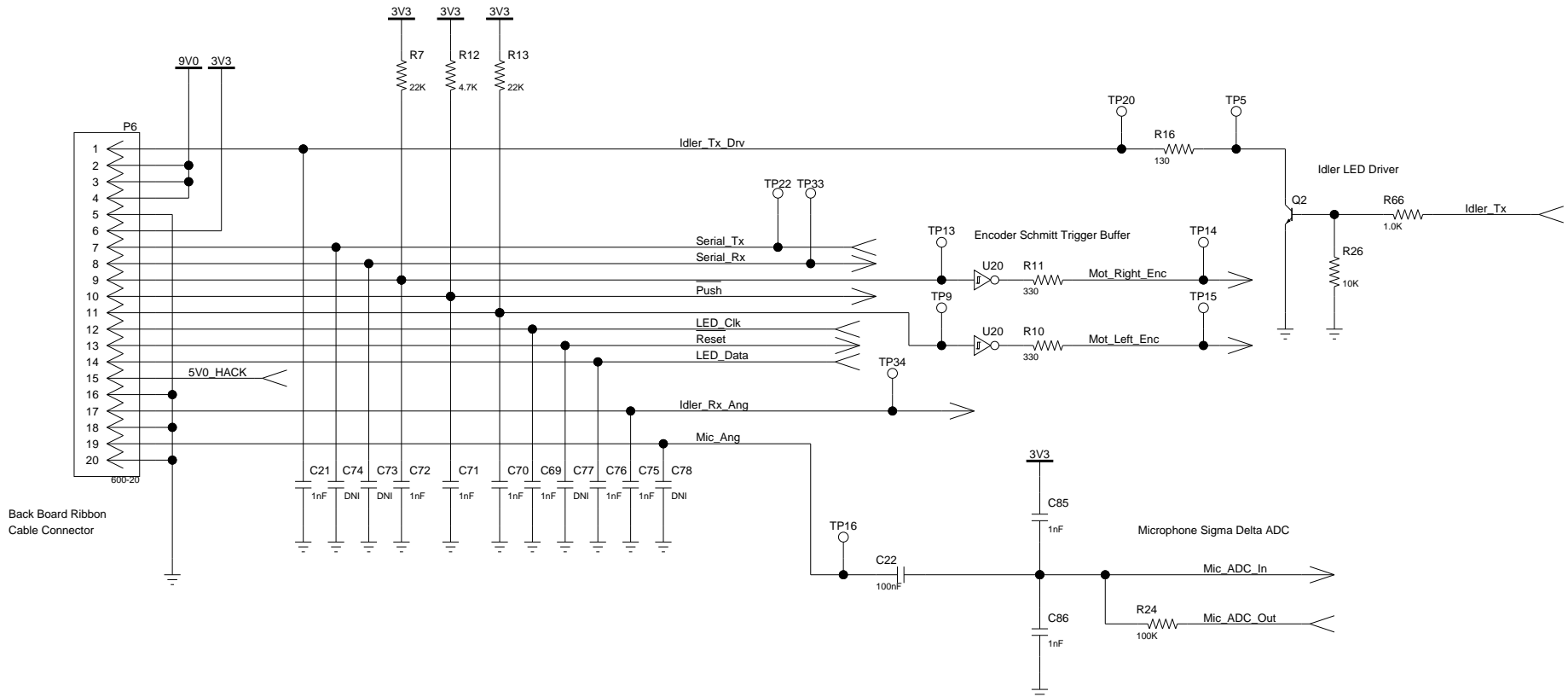

SIZE	DWG	10712D_Main_PCB		PROJECT	SCRIBBLER2
A					
DRAWN BY	SHEET	OF	PROJECT		
B. WIRZ	2	8	SCRIBBLER2		

Motor Driver

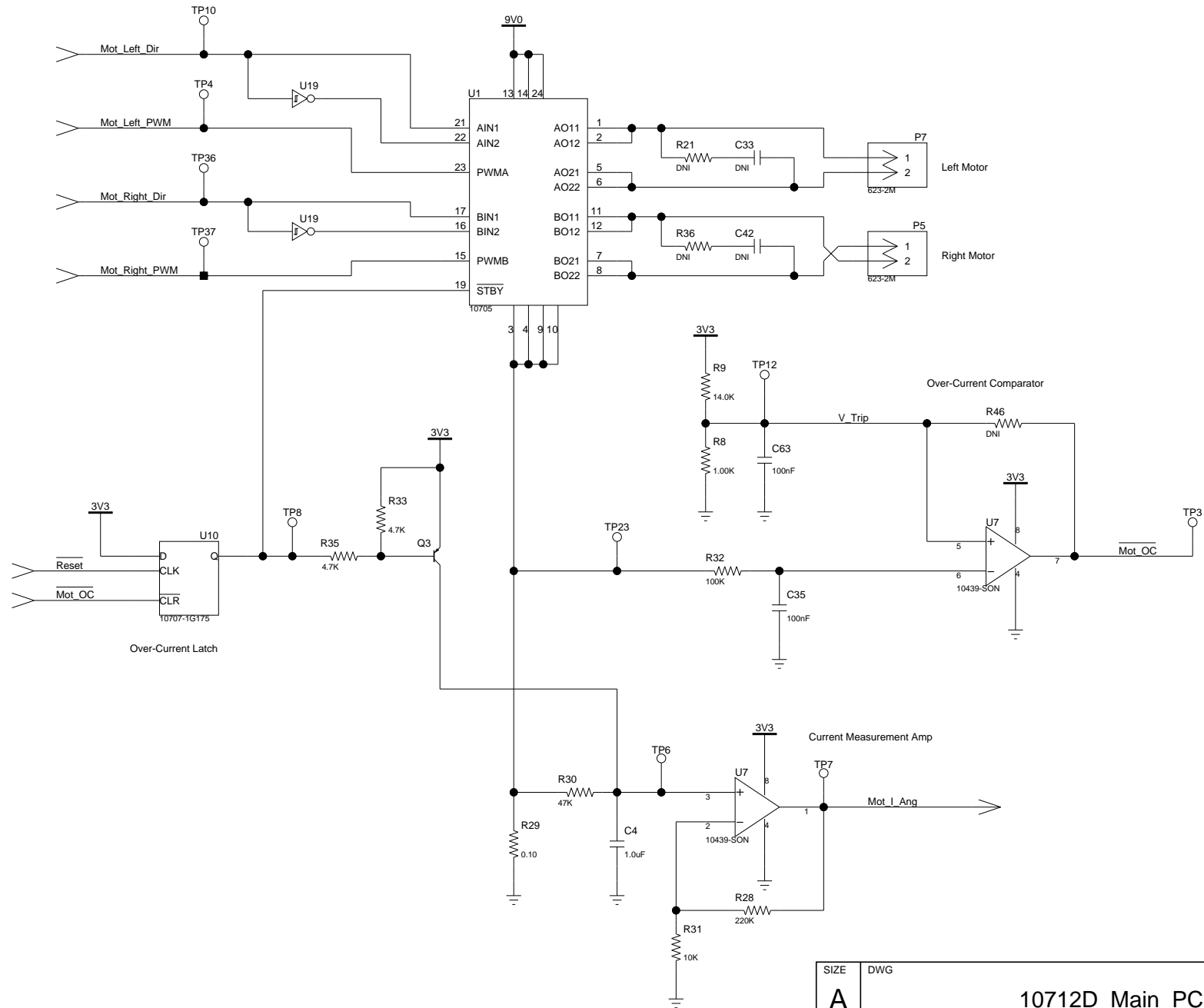

SIZE	DWG	10712D_Main_PCB	
A			
DRAWN BY	SHEET	OF	PROJECT
B. WIRZ	3	8	SCRIBBLER2

Power Supply

300kHz Switching Regulator
5.0 Vdc @ 1,800mA Max

Linear Regulator
3.3 Vdc @ 150mA Max

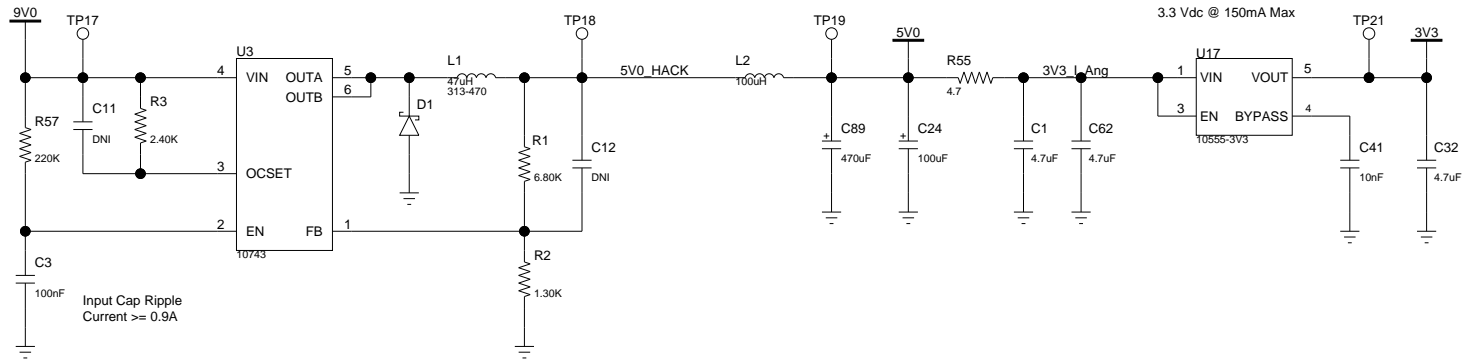

Input Cap Ripple
Current >= 0.9A

Output Cap
ESR <= 0.19 Ohm

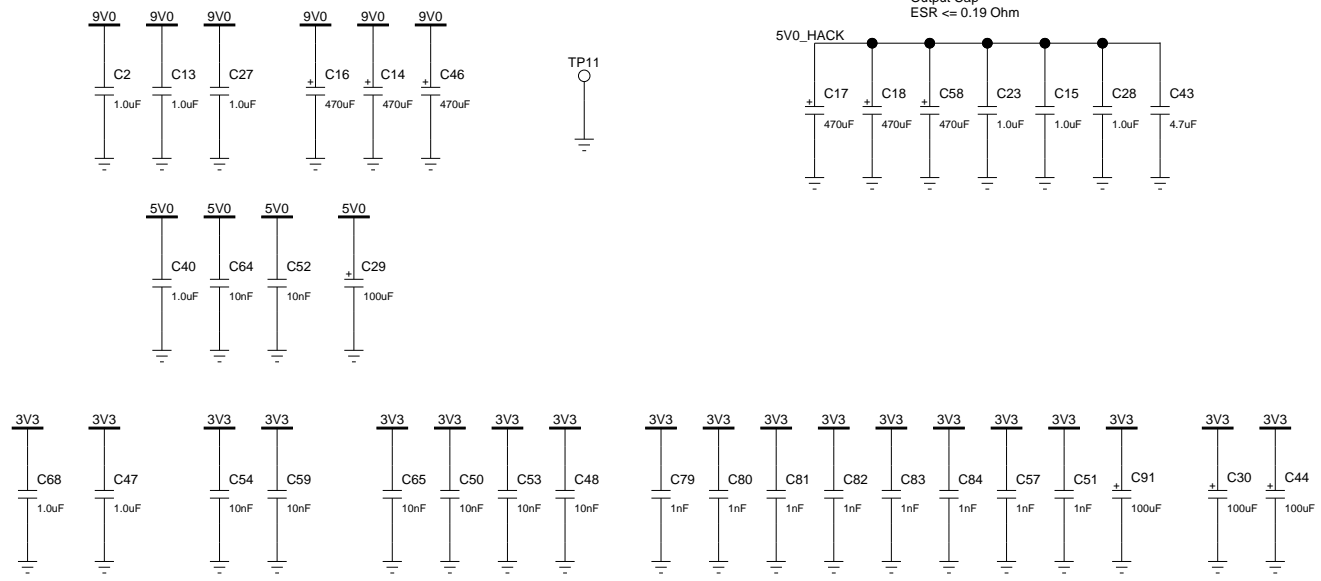

SIZE	DWG	10712D_Main_PCB	
A			
DRAWN BY B. WIRZ		SHEET OF 4 8	PROJECT SCRIBBLER2

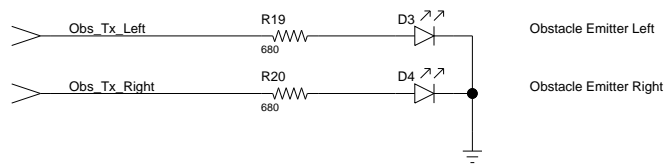
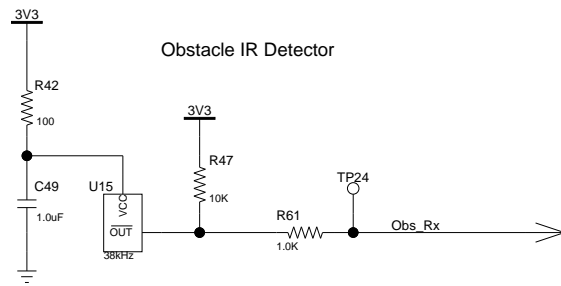
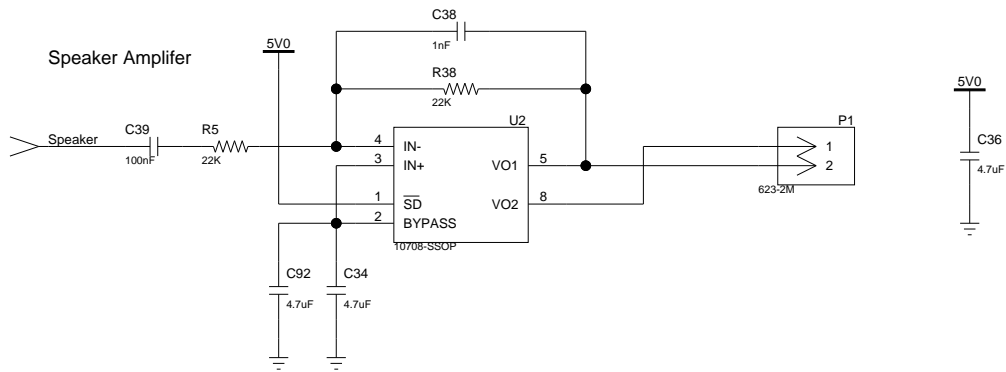

SIZE	DWG	10712D_Main_PCB	
A			
DRAWN BY	SHEET	OF	PROJECT
B. WIRZ	5	8	SCRIBBLER2

16 Channel Sigma Delta ADC

16:1 Analog Mux

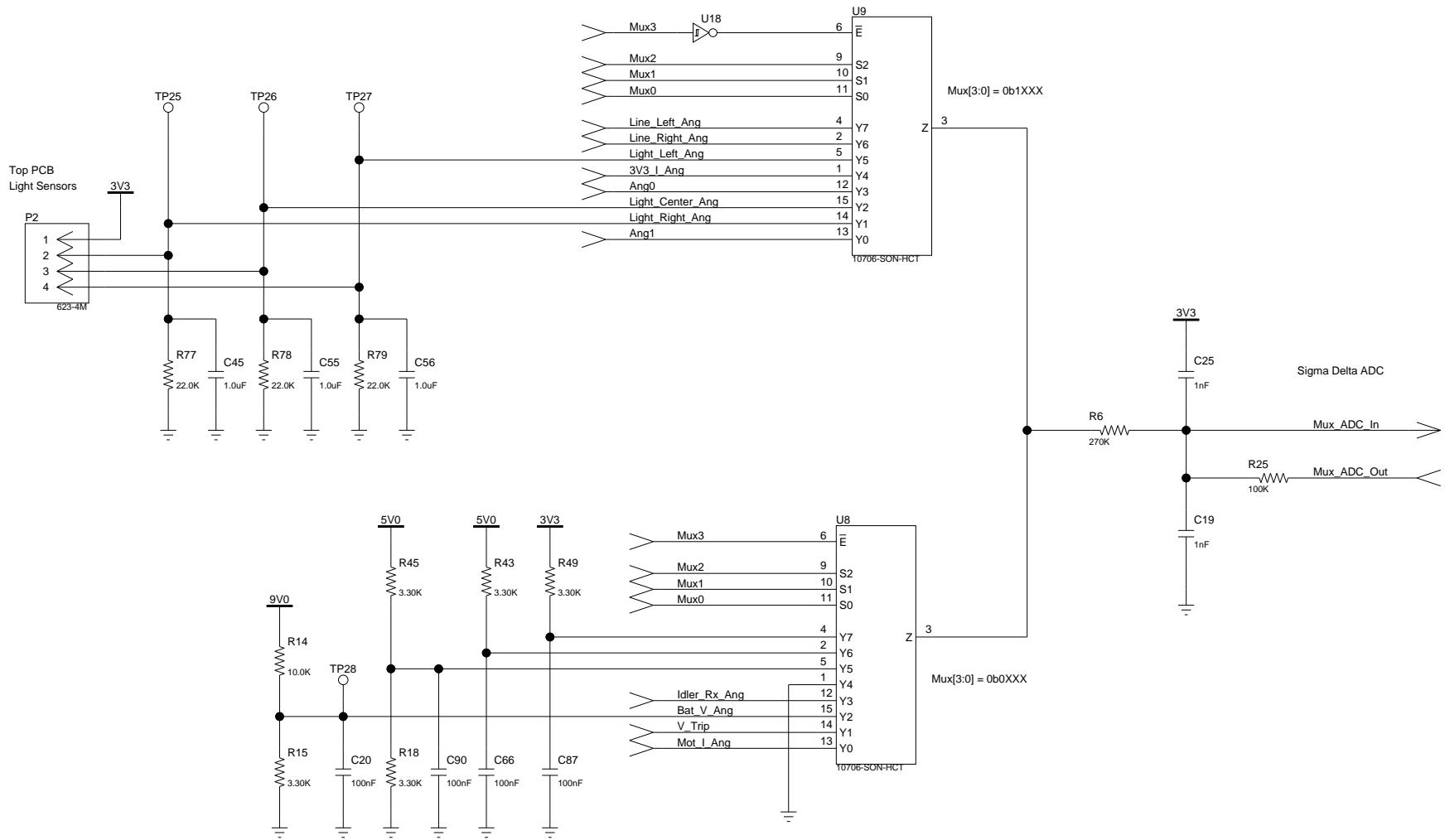

SIZE	DWG	10712D_Main_PCB	
A			
DRAWN BY	SHEET	OF	PROJECT
B. WIRZ	6	8	SCRIBBLER2

Line Follow Sensor Interface

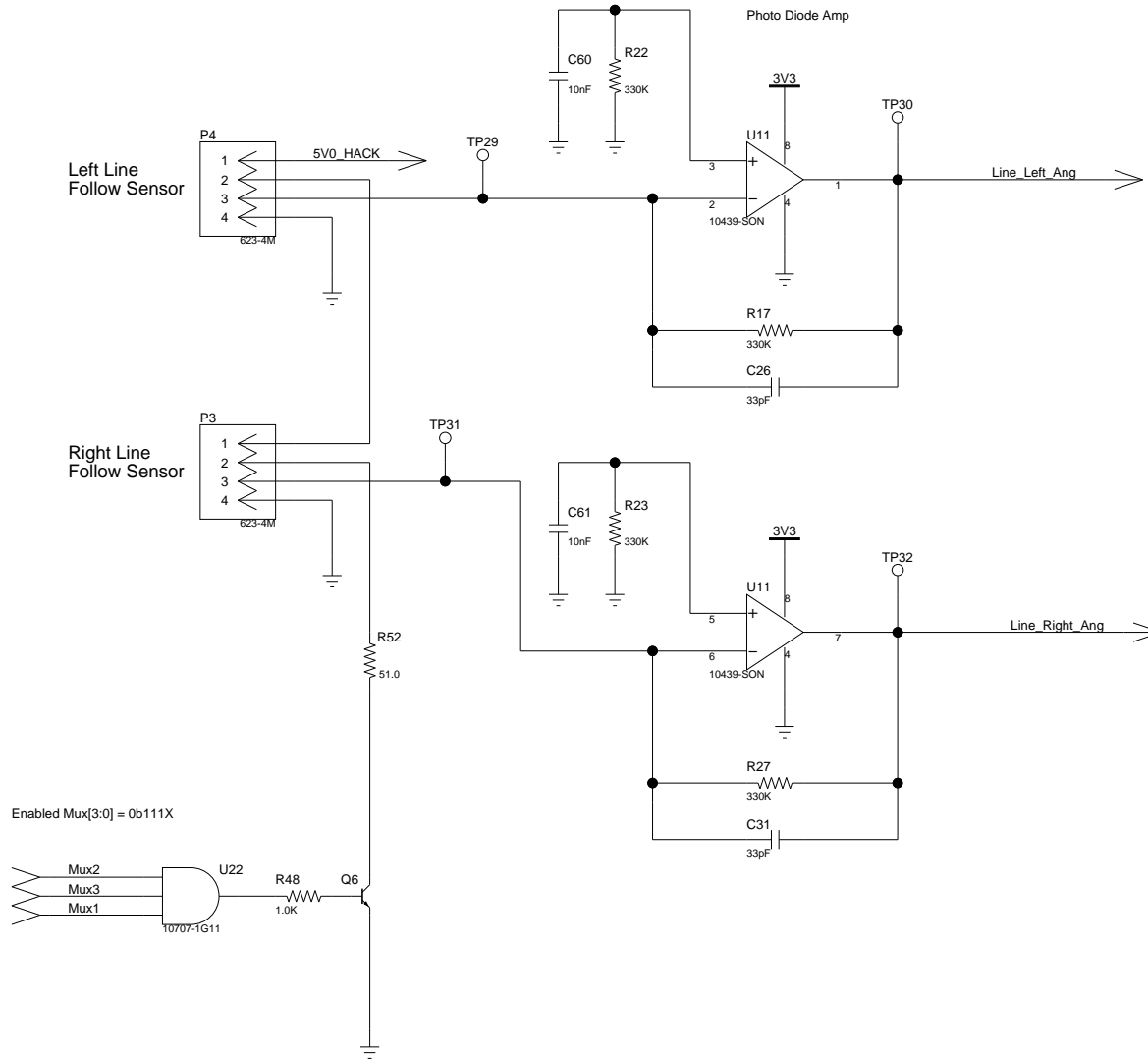

SIZE	DWG	10712D_Main_PCB	
A			
DRAWN BY	SHEET	OF	PROJECT
B. WIRZ	7	8	SCRIBBLER2

Hacker Port Interface

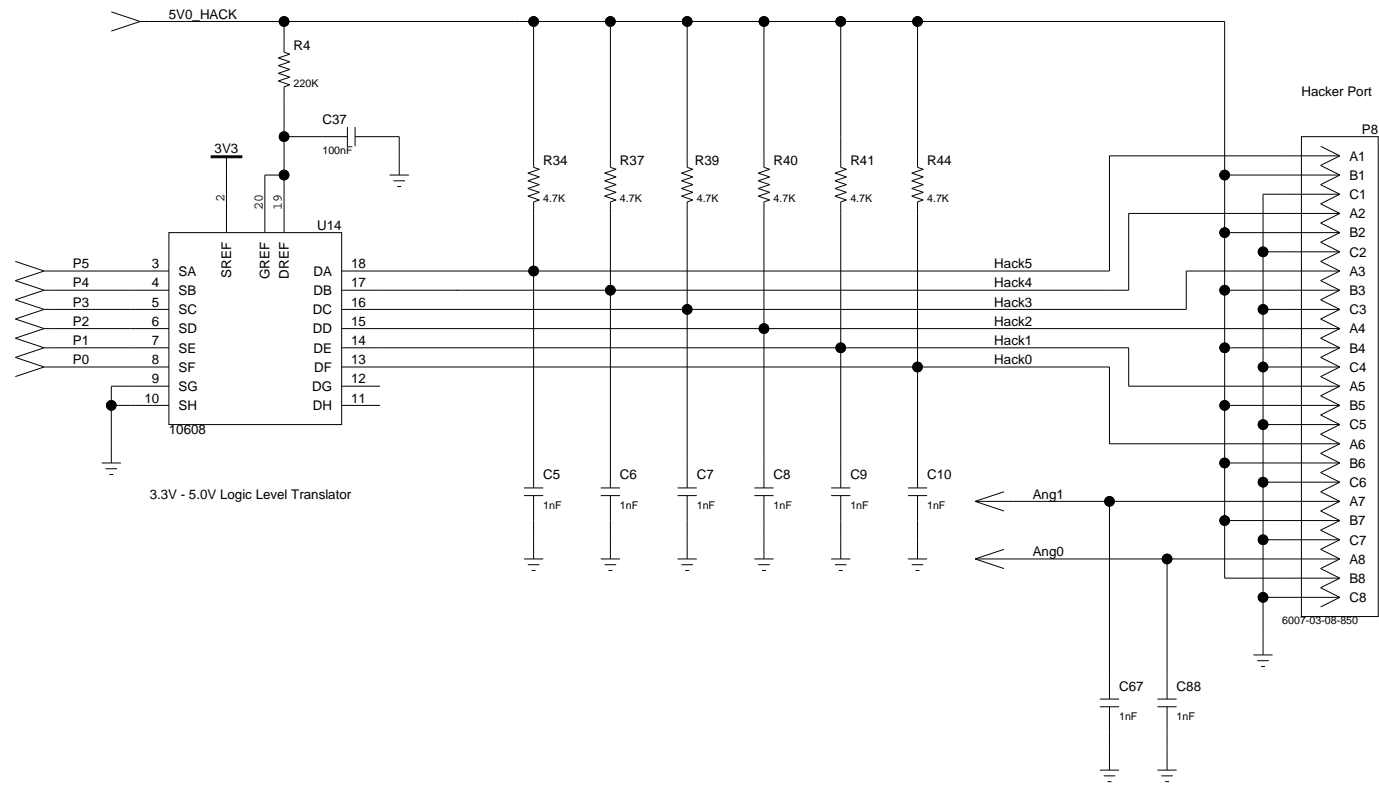

SIZE	DWG	10712D_Main_PCB		PROJECT
A				
DRAWN BY		8	8	
B. WIRZ				