

4

2 x PVC espanso 48x30x3

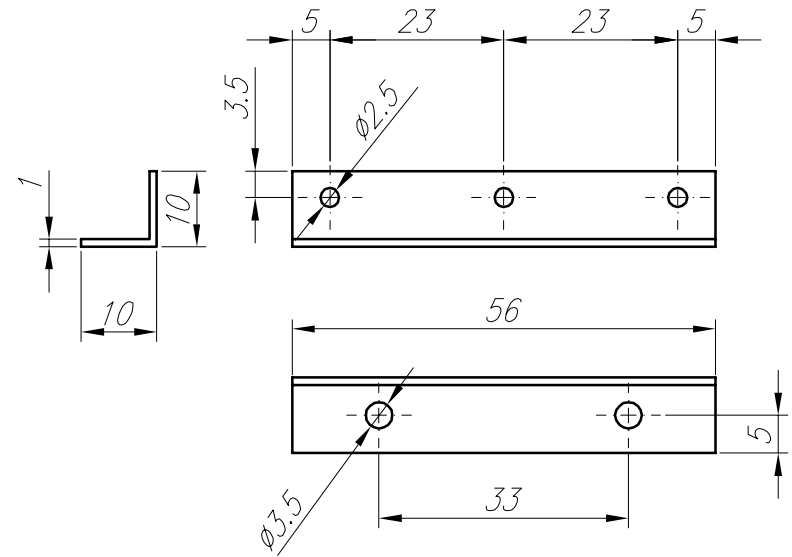

6

2 x Profilo alluminio 10x10x1 I=56

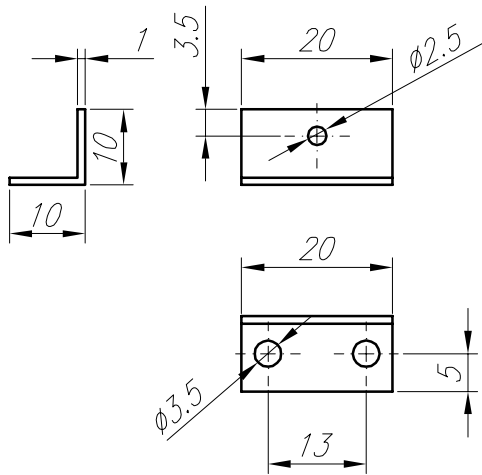

5

2 x Profilo alluminio 10x10x1 I=20

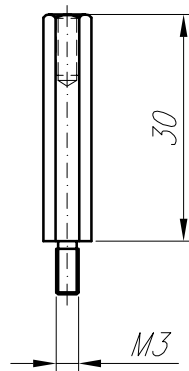

9

Distanziali esagonali
M3x20 Qta' 4

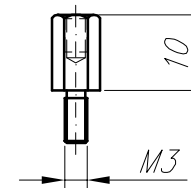

Distanziali esagonali
M3x10 Qta' 8

10

Riferimento:	3	
Progetto:	ROBOT VIKING - Ver. 1.0	
Oggetto:	PARTICOLARI TELAIO	Quantita':
Materiale grezzo:		
Progetto realizzato da Adriano Gandolfo www.adriROBOT.it		